

cussions. This work was also supported in part by the Israel Commission for Basic Research. All calculations were carried out with the CDC 6600 computer of the Tel-Aviv University Computation Center.

Registry No. I, 83220-87-5; II, 83220-88-6; III, 83220-89-7; IV,

139-91-3; V, 83220-90-0; VI, 83220-91-1.

**Supplementary Material Available:** Tables of bond distances and angles (Tables VII, VIII, and IX), as well as tables of anisotropic thermal parameters (8 pages). Ordering information is given on any current masthead page.

## Gas-Phase Heteroaromatic Substitution. 2.<sup>1</sup> Electrophilic Methylation of Pyrrole and *N*-Methylpyrrole by $\text{CH}_3\text{XCH}_3^+$ ( $\text{X} = \text{F}$ or $\text{Cl}$ ) Ions

Giancarlo Angelini, Cinzia Sparapani, and Maurizio Speranza\*

Contribution from the Istituto di Chimica Nucleare del C.N.R., Area della Ricerca di Roma, C.P. 10, Rome, Italy. Received September 17, 1981

**Abstract:** The gas-phase methylation of pyrrole (**1**) and *N*-methylpyrrole (**2**) by  $\text{CH}_3\text{XCH}_3^+$  ( $\text{X} = \text{F}$  or  $\text{Cl}$ ) ions, from the  $\gamma$  radiolysis of  $\text{CH}_3\text{X}$ , has been investigated at pressures ranging from 50 to 760 torr, in the presence of a thermal radical scavenger ( $\text{O}_2$ ) and variable concentrations of an added base ( $\text{NMe}_3$ ). Both the reactivity of the selected pyrroles relative to benzene, used as the reference substrate in competition experiments, and the isomeric distribution of their methylated derivatives depend markedly on the total pressure of the system and the concentration of  $\text{NMe}_3$ . The apparent  $k_p/k_B$  ratios increase from 0.2 (**1**)-0.3 (**2**), in neat  $\text{CH}_3\text{F}$  at 50 torr, to over 0.4 (**1**)-1.0 (**2**), at 760 torr containing 10 torr of  $\text{NMe}_3$ . Concurrently, the isomeric distribution of the methylated products changes from  $\beta:\alpha:\text{N} = 80\%:13\%:7\%$  (from **1**) and  $\beta:\alpha = 65\%:35\%$  (from **2**) to  $\beta:\alpha:\text{N} = 50\%:15\%:35\%$  and  $\beta:\alpha = 70\%:30\%$ . These results are consistent with a methylation mechanism involving kinetically predominant  $\text{CH}_3\text{FCH}_3^+$  attack on the  $\beta$ -carbons of the pyrrolic substrate and subsequent isomerization of the resulting excited intermediates to the thermodynamically most stable 3-methylpyrrole protonated on the 2-position. The substrate and positional selectivity of the gas-phase methylation and the mechanism of isomerization that appears of intramolecular nature are discussed in the light of recent theoretical predictions on heteroaromatic reactivity and compared with the available data of related methylation reactions, occurring both in the gaseous and condensed phase.

Electrophilic substitution of five-membered heteroaromatic rings is a challenging area within which the modern concepts of theoretical chemistry and chemical reactivity find not only their widest application but also their inherent limits. Despite intense kinetic and mechanistic investigations, very few quantitative data are available that allow for a direct evaluation of the reactivity scale of simple heteroaromatics. The data accumulated show that, in solution, heteroaromatic reactivity may span over many orders of magnitude with the sequential hierarchy *N*-methylpyrrole > pyrrole >> furan > thiophene > benzene.<sup>2</sup> However, no reasonable explanation for this behavior has been so far presented. Certainly, environmental factors play a decisive role in determining such a large reactivity difference. The current literature of the field is studded with evidence for profound environmental effects on the magnitude of simple physical properties of fundamental heteroaromatics that are related to their electron density distribution (e.g., the overall dipole moment). These physical alterations are reflected in dramatic effects of the reaction medium upon the reactivity features of the heteroaromatic compounds. As a consequence, most of the heteroaromatic reactivity scales from solution studies are devoid of any quantitative significance since they originate from kinetic measurements carried out under diverse environmental conditions.<sup>2,3</sup> Environmental factors often de-

termine the directive properties of a given heteroaromatic ring toward electrophilic attack as well, although  $\alpha$  substitution appears to be a general rule in solution.

From the above considerations, a detailed investigation on the reactivity features of simple five-membered heteroaromatics toward electrophilic substitution would be of special interest if carried out in the dilute gas state, where complications related to the solvent, catalyst, counterion, etc. are completely eliminated. Under such conditions, in fact, direct evaluation of the intrinsic reactivity scale of simple heteroaromatics would be at hand. The absence of environmental effects also means that the results of the gas-phase investigation can be used with some confidence for testing the validity of the theoretical predictions on the reactivity and selectivity features of heteroaromatic compounds.<sup>4-7</sup>

(3) (a) Acheson, R. M. "An Introduction to the Chemistry of Heterocyclic Compounds", 2nd Ed; Wiley: New York, 1967. (b) Robert, J. D.; Caserio, M. C. "Basic Principles of Organic Chemistry"; W. A. Benjamin: New York, 1964. (c) Paquette, L. A. "Principles of Modern Heterocyclic Chemistry"; W. A. Benjamin: New York, 1968.

(4) (a) Abbronin, I. A.; Belenkii, L. I.; Gol'dfarb, Ya. L. "New Trends in Heterocyclic Chemistry"; Elsevier: North-Holland, 1979. (b) Ridd, J. *Phys. Methods Heterocycl. Chem.* **1971**, 55-120. (c) Jones, R. A.; Bean, G. P. "The Chemistry of Pyrroles"; Academic Press: New York, 1977.

(5) (a) Epitotis, N. D.; Cherry, W. R.; Bernardi, F.; Hehre, W. J. *J. Am. Chem. Soc.* **1976**, 98, 4361-4364. (b) Gleghorn, J. T. *J. Chem. Soc., Perkin Trans. 2* **1972**, 479-482.

(6) (a) Catalan, J.; Yanez, M. *J. Chem. Soc., Perkin Trans. 2* **1979**, 1627-1631. (b) Palmer, M. H.; Gaskell, A. J. *Theor. Chim. Acta* **1971**, 23, 52-58. (c) Kramling, R. W.; Wagner, E. L. *Ibid.* **1969**, 15, 43-56.

(7) (a) Politzer, P.; Weinstein, H. *Tetrahedron* **1975**, 31, 915-923. (b) Chou, D.; Weinstein, H. *Ibid.* **1978**, 34, 275-286. (c) Politzer, P.; Donnelly, R. A.; Daiker, K. C. *J. Chem. Soc., Chem. Commun.* **1973**, 617-618. (d) Berthier, G.; Bonaccorsi, R.; Scrocco, E.; Tomasi, J. *Theor. Chim. Acta* **1972**, 26, 101-105.

(1) Presented in part at the 8th International Congress of Heterocyclic Chemistry, Graz, Austria, Aug 1981. Part I: Speranza, M. *J. Chem. Soc., Chem. Commun.* **1981**, 1177-1178.

(2) For comprehensive reviews, see: (a) Marino G. *Adv. Heterocycl. Chem.* **1971**, 13, 235-314. (b) Katritzky, A. R.; Lagowsky, J. M. "The Principles of Heterocyclic Chemistry"; Academic Press: New York, 1968. (c) Albert, A. "Heterocyclic Chemistry", 2nd ed; Oxford University Press: New York, 1968. (d) Jones, R. A. *Adv. Heterocycl. Chem.* **1970**, 11, 383.

Achievement of these goals is within the reach of a recently developed radiolytic technique that, unlike the ordinary mass spectrometry methods, allows for the kinetic analysis of gas-phase ionic reactions by the same methodology typical of solution chemistry, based inter alia on the actual isolation of the neutral end products and the determination of their isomeric composition.<sup>8</sup>

We, therefore, applied this method for a comprehensive study of gas-phase electrophilic substitution on five-membered heteroaromatics. At the present level, the study has been restricted to the gas-phase ionic methylation of pyrrole, *N*-methylpyrrole, furan, and thiophene. The dimethylhalonium ions ( $\text{CH}_3\text{XCH}_3^+$ , X = F or Cl) were selected as the methylating reactants since they can be generated in high yields in the gaseous phase by  $\gamma$  radiolysis of the parent neutral halide ( $\text{CH}_3\text{X}$ ).<sup>9</sup> They represent, by far, the major charged species (>96%) from the radiolysis of the parent halide<sup>9a</sup> and do not further react with it to any appreciable extent.<sup>10</sup> In addition, comparison of the gas-phase as opposed to condensed-phase studies should add to our understanding of the alkylation mechanism in solution, since dimethylhalonium ions are known to be involved in Friedel-Crafts methylation reactions by methyl halides.<sup>11,12</sup>

Here we study the gas-phase electrophilic attack of radiolytic  $\text{CH}_3\text{XCH}_3^+$  (X = F or Cl) ions on pyrrole (1) and *N*-methyl-



1, R = H  
2, R = CH<sub>3</sub>

pyrrole (2), and leave for the companion paper the study of the same reactions on furan and thiophene.

### Experimental Section

**Materials.** Methyl fluoride, methyl chloride, oxygen, argon, and trimethylamine (Matheson Co.) were used without further purification. Pyrrole and *N*-methylpyrrole were research grade chemicals from Fluka AG. Isomeric methyl- and dimethylpyrroles were prepared according to established procedures.<sup>13</sup> These compounds were purified by preparative GLC (5 m 25% silicone oil E 301 on Chromosorb W 60–80 mesh;  $T_c$  90 °C). Their purity was checked by GLC on the same columns employed in the analysis of the reaction mixtures.

**Procedure.** The gaseous reaction mixtures were prepared by standard vacuum techniques introducing the bulk constituent ( $\text{CH}_3\text{X}$ ; X = F or Cl) and the required additives ( $\text{O}_2$ ,  $\text{NMe}_3$ , etc.), together with weighed fragile ampules containing the heteroaromatic substrate, into carefully evacuated and outgassed Pyrex bulbs. Typical experimental conditions were as follows:  $\text{CH}_3\text{F}$ ; 50–760 torr; pyrrole 1 or 2; 0.2–0.8 torr;  $\text{O}_2$ ; 4 torr;  $\text{NMe}_3$ ; 0–10 torr. After the fragile ampule was broken and its contents were completely mixed in the gas phase, the gaseous mixtures were irradiated with <sup>60</sup>Co  $\gamma$  rays in a 220 Gammacell (Nuclear Canada,

(8) For comprehensive reviews, see: (a) Ausloos, P. *Annu. Rev. Phys. Chem.* **1966**, *17*, 205–236. (b) Ausloos, P. *Prog. React. Kinet.* **1969**, *5*, 113–179. (c) Ausloos, P.; Lias, S. G. "Ion-Molecule Reactions"; Franklin, J. L., Ed.; Plenum Press: New York, 1972. (d) Cacace, F. "Kinetics of Ion-Molecule Reactions"; Ausloos, P., Ed.; Plenum Press: New York, 1979.

(9) (a) Speranza, M.; Pepe, N.; Cipollini, R. *J. Chem. Soc., Perkin Trans. 2* **1979**, 1179–1186. (b) Pepe, N.; Speranza, M. *Ibid.* **1981**, 1430–1436. (c) Speranza, M.; Angelini, G. *J. Am. Chem. Soc.* **1980**, *102*, 3115–3120. (d) Angelini, G.; Speranza, M. *Ibid.* **1981**, *103*, 3792–3799. (e) *Ibid.* **1980**, 3800–3806. (f) Colosimo, M.; Bucci, R. *J. Phys. Chem.* **1979**, *83*, 1952–1957.

(10) (a) Luczynsky, Z.; Herman, J. A. *J. Phys. Chem.* **1978**, *89*, 179–183. (b) Benzra, S. A.; Hoffman, M. K.; Bursley, M. M. *J. Am. Chem. Soc.* **1970**, *92*, 7501–7502. (c) Pabst, M. J. K.; Tan, H. S.; Franklin, J. L. *Int. J. Mass Spectrom. Ion Phys.* **1976**, *20*, 191–221. (d) Blint, R. J.; McMahon T. B.; Beauchamp, J. L. *J. Am. Chem. Soc.* **1974**, *96*, 1269–1278. (e) Beauchamp, J. L.; Holtz, D.; Woodgate, S. D.; Patt, S. L. *Ibid.* **1972**, *94*, 2798–2807. (f) Holtz, D.; Beauchamp, J. L.; Woodgate, S. D. *Ibid.* **1970**, *92*, 7484–7486. (g) Herod, A. A.; Harrison, A. G.; McAskill, N. A. *Can. J. Chem.* **1971**, *49*, 2217–2222.

(11) (a) Olah, G. A. "Halonium Ions"; Olah, G. A., Ed.; Wiley: New York, 1975. (b) Olah, G. A.; DeMember, J. R. *J. Am. Chem. Soc.* **1970**, *92*, 718–720. (c) Olah, G. A.; Melby, E. G. *Ibid.* **1972**, *94*, 6220–6221. (d) Olah, G. A.; Yamada, Y.; Spear, R. J. *Ibid.* **1975**, *97*, 680–681. (e) Peterson, P. E.; Brockington, R.; Vidrine, D. W. *Ibid.* **1976**, *98*, 2660–2661. (f) Olah, G. A.; Donovan, D. J.; Lin, H. C. *Ibid.* **1976**, 2661–2663.

(12) Nicoletti, R.; Germani, C. *Ric. Sci.* **1966**, *36*, 1343–1346.

(13) (a) Shell, P. S.; Bean, G. P. *J. Am. Chem. Soc.* **1962**, *84*, 4655–4660. (b) Hinman, R. L.; Theodoropoulos, S. *J. Org. Chem.* **1963**, *28*, 3052–3058.

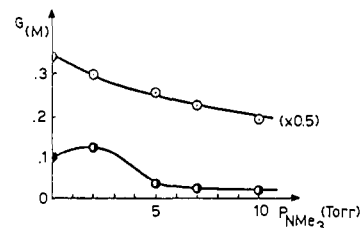

**Figure 1.** System:  $\text{CH}_3\text{F}$  (740–760 torr) + pyrrole 1 (0.3–0.5 torr) + benzene (1.5–1.7 torr) +  $\text{O}_2$  (4 torr). Dependence of the  $G_M$  values on the partial pressure of  $\text{NMe}_3$  ( $P_{\text{NMe}_3}$ ): (●) methylpyrroles 2–4; (○) toluene.

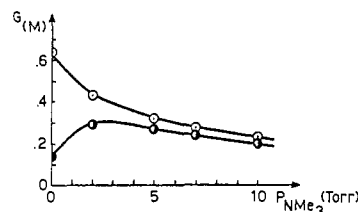

**Figure 2.** System:  $\text{CH}_3\text{F}$  (740–760 torr) + *N*-methylpyrrole (2) (1.2–1.4 torr) + benzene (1.9–2.1 torr) +  $\text{O}_2$  (4 torr). Dependence of the  $G_M$  values on the partial pressure of  $\text{NMe}_3$  ( $P_{\text{NMe}_3}$ ): (●) dimethylpyrroles 5 and 6; (○) toluene.

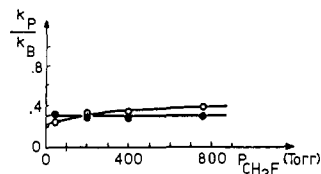

**Figure 3.** Dependence of the apparent  $k_p/k_B$  ratios (see text) on the total pressure of the competition systems: (○) pyrrole 1/benzene; (●) *N*-methylpyrrole (2)/benzene.

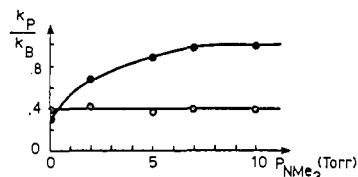

**Figure 4.** Dependence of the apparent  $k_p/k_B$  ratios (see text) on the partial pressure of  $\text{NMe}_3$  ( $P_{\text{NMe}_3}$ ), at a total pressure of 760 torr: (○) pyrrole 1/benzene; (●) *N*-methylpyrrole (2)/benzene.

Ltd.) at 37.5 °C, at dose rate of 0.30 Mrd  $\text{h}^{-1}$  to a total dose of 4.8 Mrd as determined by a Fricke dosimeter. Control experiments, carried out at doses ranging from 1 to 10 Mrd, showed that the relative yields of products and their isomeric composition are largely independent of the dose.

The analysis of the products was performed by injecting measured aliquots of the homogeneous reaction mixture into a Perkin-Elmer Model Sigma 3 gas chromatograph, equipped with a FID unit. For prevention of selective losses of the reaction products by absorption on the glass of the reaction bulb (and for reproducible and meaningful reaction yield), the analysis was repeated after careful washing of the bulb walls with freshly purified ethyl acetate. Satisfactory agreement between the results of the gaseous mixture and the ethyl acetate solution analysis was found in all runs. The products were identified by comparison of their retention volumes with those of the authentic standard compounds. Appropriate calibration curves for the detector response were employed to measure the yields of each product. The identity of the products was further confirmed by GLC-MS, using a Micromass VG 7070 mass spectrometer. The same instrument, operated in the chemical ionization (CI) mode, was employed for the CI experiments. The reagent gas ( $\text{CH}_3\text{X}$ ; X = F or Cl) pressure in the source was directly measured with a Bourdon gauge, inserted in place of the direct introduction probe.

### Results

**Product Yields.** Gas-phase attack of radiolytic  $\text{CH}_3\text{FCH}_3^+$  ions on pyrrole (1) and *N*-methylpyrrole (2) yields the corresponding methylated derivatives, namely methyl- (2–4) and dimethylpyrroles

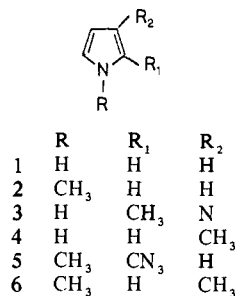

(5 and 6), respectively. Their absolute yields, expressed as the number of molecules *M* produced per 100 eV of energy absorbed by the gaseous mixtures ( $G_M$  values), have been measured under various experimental conditions, at the constant temperature of 37.5 °C and for the total dose of 4.8 Mrd (dose rate 0.30 Mrd h<sup>-1</sup>).

Figures 1 and 2 show the results of competition experiments, with benzene as the reference substrate, carried out at a total pressure of 760 torr and in the presence of variable concentrations (0–10 torr) of an efficient ion trapper, such as NMe<sub>3</sub>. Specifically, Figure 1 refers to the experiments on **1** while those pertaining to **2** are reported in Figure 2. The resulting apparent ratios of the specific rate constants,  $k_p/k_B$ , defined as the  $G_{2-4 \text{ or } 5-6} \times [\text{benzene}] / G_{\text{toluene}} \times [1]$  or  $[2]$  given in Figure 4. The dependence of the  $k_p/k_B$  values upon the total pressure of the system is shown in Figure 3.

The data reported in Figures 1–4, as well as those presented in the following sections, represent the average of at least three runs and are affected by a standard deviation of ca. 10%. Control runs were also carried out by irradiating systems of comparable composition, except for the replacement of CH<sub>3X</sub> with a noble gas, with similar ionization potential, such as Ar. The pertinent results have confirmed that the methylated products (2–6) originated solely from radiolysis of CH<sub>3X</sub> gas.

Comparative analysis of Figures 1 and 2 shows that the total product yield of CH<sub>3FCH<sub>3</sub><sup>+</sup> methylation is dependent on the presence and concentration of NMe<sub>3</sub> and the nature of the pyrrolic substrate. Thus, while the toluene yield monotonically decreases by increasing NMe<sub>3</sub> concentration, the overall yield of the pyrrolic products reaches the maximum value in the presence of 2–3 torr of NMe<sub>3</sub> and decreases upon further addition of the base.</sub>

From the general trends shown in Figures 1 and 2, regarding the effect of NMe<sub>3</sub> on  $G_M$  values, the following will be appreciated:

(i) The ionic nature of the methylation process is substantiated by the significant decrease of the  $G_M$  values at high NMe<sub>3</sub> concentrations.

(ii) Direct attack of CH<sub>3FCH<sub>3</sub><sup>+</sup> ions on **1** or **2** induces a complex reaction pattern, in analogy with a similar behavior observed in independent investigations.<sup>9a,c</sup></sub>

(iii) The complex reaction pattern involves a methylation reaction accompanied by secondary processes not leading to any isolable products (e.g., ring opening, polymerization, etc.) (the methylated substrates account for over 85% of the recovered reaction products).

(iv) The relative extent of the secondary processes does not exceed 50% in the absence of base (as computed from a comparison of the measured overall  $G_M$  value with that reported in related studies<sup>9a,b</sup>) and is appreciably depressed in favor of the substitution path in the presence of NMe<sub>3</sub>.

In the CH<sub>3Cl</sub> experiments, gas-phase attack of radiolytic CH<sub>3ClCH<sub>3</sub><sup>+</sup> ions on the pyrrolic substrates **1** and **2** does not lead to any significant formation of the corresponding methylated products. In fact, very low yields ( $G_M \leq 2 \times 10^{-3}$ ) of the  $\beta$ -substituted isomers (4 and 6) were found.</sub>

**Chemical Ionization (CI) Mass Spectrometric Experiments.** For investigation of the nature of intermediate species formed in the reaction of CH<sub>3FCH<sub>3</sub><sup>+</sup> with **1** and **2**, the CH<sub>3F</sub> CI mass spectra of the selected pyrrolic substrates were recorded in the pressure range from 0.1 to ca. 1.0 torr, at an ion-source temperature of 200 °C, by introducing a CH<sub>3F</sub> + 0.6 mol % of **1** (or **2**) gaseous</sub>

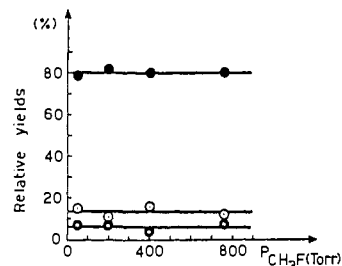

**Figure 5.** Relative yields of isomeric methylpyrroles **2–4** from CH<sub>3FCH<sub>3</sub><sup>+</sup> attack on pyrrole **1** as a function of the total pressure ( $P_{\text{CH}_3\text{F}}$ ) of the system, in the absence of NMe<sub>3</sub>: (●) 3-methylpyrrole (**4**); (⊙) 2-methylpyrrole (**3**); (○) *N*-methylpyrrole (**2**).</sub>

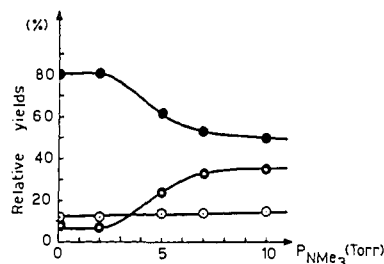

**Figure 6.** Relative yields of isomeric methylpyrroles **2–4** from CH<sub>3FCH<sub>3</sub><sup>+</sup> attack on pyrrole **1**, at 760 torr, as a function of the partial pressure of NMe<sub>3</sub> ( $P_{\text{NMe}_3}$ ): (●) 3-methylpyrrole (**4**); (⊙) 2-methylpyrrole (**3**); (○) *N*-methylpyrrole (**2**).</sub>

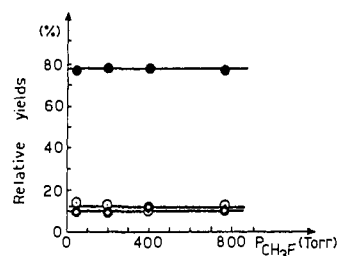
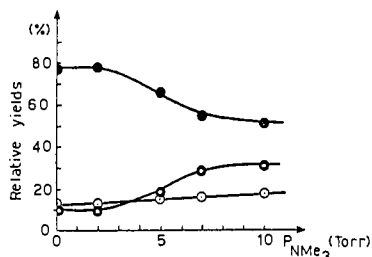

**Figure 7.** Relative yields of isomeric methylpyrroles **2–4** from pyrrole **1** in the competition experiments, as a function of the total pressure ( $P_{\text{CH}_3\text{F}}$ ) of the system, in the absence of NMe<sub>3</sub>: (●) 3-methylpyrrole (**4**); (⊙) 2-methylpyrrole (**3**); (○) *N*-methylpyrrole (**2**).

mixture into the mass spectrometer.

CH<sub>3FCH<sub>3</sub><sup>+</sup> is the most abundant high-order ion formed from pure CH<sub>3F</sub> in the pressure range investigated. When traces (0.6 mol %) of **1** (or **2**) are added to the CH<sub>3F</sub> gas, the corresponding (*M* + 15)<sup>+</sup> and (*M* + 13)<sup>+</sup> ions are formed readily. Their relative intensity depends on both the ion-source pressure and the nature of the pyrrolic substrate. In particular, the intensity ratio (*M* + 15)<sup>+</sup>/*(M* + 13)<sup>+</sup> from **1** decreases from 0.53 at ca. 1.0 torr to 0.19 at 0.1 torr. A more pronounced decrease is observed in the case of **2** (from 0.70 at 1.0 torr to 0.12 at 0.1 torr). These results substantiate a pyrrole methylation process ((*M* + 15)<sup>+</sup>) which is accompanied by partial fragmentation of the resulting adduct to give (*M* + 13)<sup>+</sup>, whose extent is reduced by increasing the source pressure. It is worth noting that collisional quenching of the ion precursor of (*M* + 13)<sup>+</sup> is apparently more efficient for **2** than **1**. The CI data are, therefore, in qualitative agreement with the results of radiolytic experiments and suggest the occurrence of extensive methylation by attack of CH<sub>3FCH<sub>3</sub><sup>+</sup> on the pyrrolic substrates.</sub></sub>

The agreement between CI and radiolytic experiments also applies to the relatively scarce reactivity of CH<sub>3ClCH<sub>3</sub><sup>+</sup> ion toward the selected pyrroles. CH<sub>3Cl</sub> CI mass spectra of **1** and **2** (0.6 mol %), in fact, revealed that the overall relative abundance of the methylation ions ((*M* + 15)<sup>+</sup> + (*M* + 13)<sup>+</sup>) does not exceed 2% of the intensity of the CH<sub>3ClCH<sub>3</sub><sup>+</sup> ions, whereas the yield of the methylation species from heterocyclic compounds with *n* electrons, e.g., furan (see the accompanying paper), is more than 10% of the CH<sub>3ClCH<sub>3</sub><sup>+</sup> ion intensity, under the same conditions.</sub></sub></sub>



**Figure 8.** Relative yields of isomeric methylpyrroles 2-4 from pyrrole 1 in the competition experiments, at 760 torr, as a function of the partial pressure  $NMe_3$  ( $P_{NMe_3}$ ): (●) 3-methylpyrrole (4); (○) 2-methylpyrrole (3); (○) *N*-methylpyrrole (2).

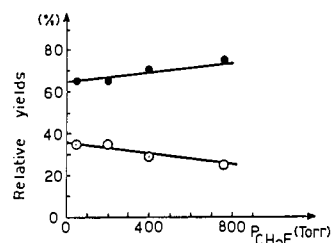

**Figure 9.** Relative yields of isomeric dimethylpyrroles 5-6 from  $CH_3FCH_3^+$  attack on *N*-methylpyrrole (2) as a function of the total pressure ( $P_{CH_3F}$ ) of the system, in the absence of  $NMe_3$ : (●) 1,3-dimethylpyrrole (6); (○) 1,2-dimethylpyrrole (5).

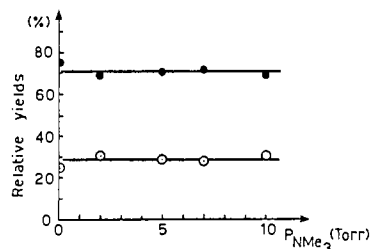

**Figure 10.** Relative yields of isomeric dimethylpyrroles 5-6 from  $CH_3FCH_3^+$  attack on *N*-methylpyrrole (2), at 760 torr, as a function of the partial pressure of  $NMe_3$  ( $P_{NMe_3}$ ): (●) 1,3-dimethylpyrrole (6); (○) 1,2-dimethylpyrrole (5).

**Methylated Product Distribution.** Figures 5-8 report on the isomeric composition of the products from  $CH_3FCH_3^+$  methylation of pyrrole 1, either neat (Figures 5 and 6) or in competition with benzene (Figures 7 and 8).

The product distribution from  $CH_3FCH_3^+$  methylation of *N*-methylpyrrole 2 as a function of the system pressure and of the  $NMe_3$  concentration is shown in Figures 9-12. In this case, it should be noted that the only methylated derivatives of 2, recovered in the irradiated mixtures, were dimethylpyrroles (5 and 6). The yield of other conceivable dimethylpyrroles, whose formation involves migration of the  $CH_3$  group originally bonded to the N atom of the substrate, was below the detection limit ( $G_M < 1 \times 10^{-4}$ ).

Inspection of Figures 5-12 shows that  $\beta$ -methylation of the selected pyrroles predominates under all experimental conditions. The isomeric distribution of methylpyrroles 2-4 from 1 is practically independent of the total pressure of the system (Figure 5). The relative yield of 3-methylpyrrole (4) exceeds those of 2 and 3 by factors of 5 and 10, respectively. At atmospheric pressure, the isomeric distribution of 2-4 changes significantly with the concentration of  $NMe_3$ : it reaches a 50% (4), 15% (3), 35% (2) composition at 10 torr of  $NMe_3$  (Figure 6). This picture is not significantly modified by the presence of benzene in the irradiated mixtures (Figures 7 and 8).

The relative distribution of 1,2-dimethylpyrrole (5) and 1,3-dimethylpyrrole (6) from 2 (Figures 9-12) also shows a predominance of the  $\beta$ -substituted isomer (i.e., 6). Its relative yield does not vary greatly in the presence of  $NMe_3$  (70%) (Figure 10), although a slight decrease with the system pressure is noted that

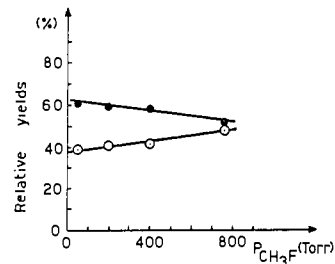

**Figure 11.** Relative yields of isomeric dimethylpyrroles 5-6 from *N*-methylpyrrole (2) in the competition experiments, as a function of the total pressure ( $P_{CH_3F}$ ) of the system, in the absence of  $NMe_3$ : (●) 1,3-dimethylpyrrole (6); (○) 1,2-dimethylpyrrole (5).

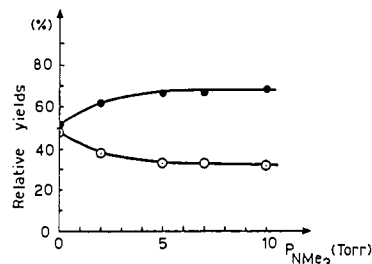

**Figure 12.** Relative yields of isomeric dimethylpyrroles 5-6 from *N*-methylpyrrole (2) in the competition experiments, at 760 torr, as a function of the partial pressure of  $NMe_3$  ( $P_{NMe_3}$ ): (●) 1,3-dimethylpyrrole (6); (○) 1,2-dimethylpyrrole (5).

levels off to a value of ca. 65% below 200 torr (Figure 9). In the competition experiments the presence of benzene modifies appreciably the dimethylpyrrole distribution and, therefore, enhances the relative yield of 5 (cf. Figures 9-12). It is interesting to note that, while the 5:6 distribution of Figures 9 and 10 is scarcely affected by the experimental conditions, the isomeric distribution arising from the competition experiments turns out to depend largely upon both the total pressure of the system (Figure 11) and the concentration of the added  $NMe_3$  (Figure 12).

In conclusion, the major features of the gas-phase  $CH_3XCH_3^+$  ( $X = F$  or  $Cl$ ) methylation of the selected pyrroles can be summarized as follows:

(i) Pyrroles 1 and 2, as well as benzene, are efficiently methylated by  $CH_3FCH_3^+$  ions, whereas the  $CH_3ClCH_3^+$  species appears rather unreactive.

(ii)  $CH_3FCH_3^+$  methylation of 1 and 2 is accompanied by collateral parasitic processes that can be inhibited, in part, by addition of suitable amounts of  $NMe_3$ . This is especially true in the case of 2.

(iii) Formation of the  $\beta$ -methylated isomer (4 from 1 and 6 from 2) predominates under all experimental conditions. Significant substitution on the N atom of 1 also takes place.

(iv) The isomeric distribution of methylated derivatives of 1 is largely independent of the total pressure but is influenced by addition of  $NMe_3$  to the system.

(v) The isomeric distribution of the methylated products from 2 seems to be insensitive to the experimental conditions. However, in the presence of benzene, the relative yield of the  $\alpha$ -substituted product is enhanced.

## Discussion

**Nature and Reactivity of the Methylating Electrophiles.** As extensively discussed in related papers,<sup>9</sup> the reagent formed in the radiolytic experiments is the thermal  $CH_3XCH_3^+$  ( $X = F$  or  $Cl$ ) ion. It is produced in good yields from the radiolysis of the  $CH_3X$  ( $X = F$  or  $Cl$ ) and is completely unreactive toward the parent halide.<sup>10</sup> Thermal  $CH_3FCH_3^+$  ion ( $\Delta H_f^\circ = 161 \pm 8 \text{ kcal mol}^{-1}$ )<sup>10e</sup> is known to behave as a pure Lewis acid that attacks both  $n$ - and  $\pi$ -type substrates. On the contrary,  $CH_3ClCH_3^+$  ( $\Delta H_f^\circ \leq 189 \text{ kcal mol}^{-1}$ )<sup>10e</sup> is a good methylating agent for  $n$ -type centers;<sup>9</sup> this is confirmed by the present investigation. In this case, the absence of significant product yields, while confirming the aromatic character of 1 and 2 in the gas phase, also substantiates the scarce

Table I. Methyl Cation Affinities of Various Species<sup>a</sup>

species	MCA, kcal mol <sup>-1</sup>	source
CH <sub>3</sub> F	44 ± 8	ref 10e
CH <sub>3</sub> Cl	≥ 51	ref 10e
C <sub>6</sub> H <sub>6</sub>	88	ref 9a
NH <sub>3</sub>	102	ref 9a
N(CH <sub>3</sub> ) <sub>3</sub>	~140	ref 14
pyrrole	~115	ref 15
N-methylpyrrole	~122	ref 15

<sup>a</sup> Methyl cation affinities (MCA) as defined in ref 10e.

reactivity of CH<sub>3</sub>ClCH<sub>3</sub><sup>+</sup> ion even toward very activated pure π-type substrates, like the selected pyrroles.

The methylation of pyrroles **1** and **2**, as well as of the reference benzene, by the dimethylhalonium ions is an energetically favorable process (Table I) and represents the only significant reaction channel available to CH<sub>3</sub>FCH<sub>3</sub><sup>+</sup> ions. Hence, the reactivity ratios, established by the competition experiments, refer exclusively to the methylation channel. They clearly provide a reasonable measure of the apparent overall nucleophilicity of the selected pyrroles toward CH<sub>3</sub>FCH<sub>3</sub><sup>+</sup>.

**Methylation Process.** The results of the radiolytic experiments and the CI mass spectrometric evidence are consistent with the methylation pattern (eq 1 and 2). It consists in the primary attack of CH<sub>3</sub>FCH<sub>3</sub><sup>+</sup> on the pyrrolic substrate, which leads to intermediate I, excited by the exothermicity of its formation process (ΔH<sub>f</sub><sup>o</sup> = -(60–90) kcal mol<sup>-1</sup>).

Several reaction channels are open to the excited intermediate I. A direct route to the methylated products is represented by collisional stabilization of the excited intermediate I, followed by loss of a proton to a suitable base B (NMe<sub>3</sub> or another molecule of substrate),<sup>16</sup> as illustrated in eq 1a. Otherwise, the excited intermediate I may undergo several secondary reactions (eq 1b),

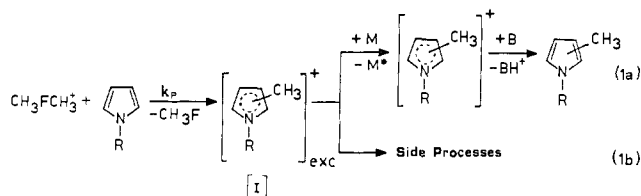

not leading to isolable products (e.g., polymerization, etc.).<sup>17</sup> As

(14) The MCA values for the (CH<sub>3</sub>)<sub>x</sub>NH<sub>3-x</sub> series (x = 0–2) have been obtained from the proton affinities (PA) of the corresponding (CH<sub>3</sub>)<sub>x+1</sub>NH<sub>2-x</sub> terms (Aue, D. H.; Webb, H. M.; Bowers, M. T. *J. Am. Chem. Soc.* 1972, 94, 4726–4728). The following MCA scale (kcal mol<sup>-1</sup>) is obtained: NH<sub>3</sub> (102) < CH<sub>3</sub>NH<sub>2</sub> (114) < (CH<sub>3</sub>)<sub>2</sub>NH (127). It should be noted that replacement of a hydrogen of the amine with a methyl group increases the MCA by value of ca. 13 kcal mol<sup>-1</sup>. On these grounds, it is possible to roughly calculate the MCA of N(CH<sub>3</sub>)<sub>3</sub> by extrapolating the above sequence. The computed MCA (NMe<sub>3</sub>) value is ca. 140 kcal mol<sup>-1</sup>.

(15) A tentative estimate of the MCA of pyrroles **1** and **2** can be arrived at by considering the reactions:

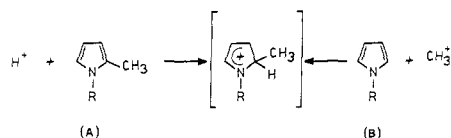

and by assuming that the PA of A at the ring position bearing the methyl group is very close to that of the corresponding pyrrole B (Devlin, J. L., III; Wolf, J. F.; Taft, R. W.; Hehre, W. J.; McIver, R. T., Jr.; Pople, J. A.; Schleyer, P. v. R. *J. Am. Chem. Soc.* 1974, 96, 7162–7163); namely, PA(**1**) = 213 kcal mol<sup>-1</sup> and PA(**2**) = ca. 220 kcal mol<sup>-1</sup> (Aue, D. H.; Webb, H. M.; Bowers, M. T. *Ibid.* 1972, 94, 4726–4728). The ΔH<sub>f</sub><sup>o</sup> of **1** (26 kcal mol<sup>-1</sup>) has been taken from Cox and Pilcher (Cox, J. D.; Pilcher, G. "Thermochemistry of Organic and Organometallic Compounds"; Academic Press: New York, 1970). The ΔH<sub>f</sub><sup>o</sup>'s of **2** (ca. 17 kcal mol<sup>-1</sup>) and 1,2-dimethylpyrrole (ca. 8 kcal mol<sup>-1</sup>) have been calculated from that of **1** by using the group additivity rules (Benson, S. W., "Thermochemical Kinetics", 2nd ed.; Wiley: New York, 1976).

(16) Other gaseous bases available to intermediate (I) would be formed from the γ radiolysis of the batch gas.

(17) The radiolytic and CI experiments do not allow one to exclude that side processes (1b) can involve also ionic species from the methylation-induced ring opening of the heterocyclic substrate.

as a consequence, it should be observed that the apparent  $k_p/k_B$  values of Figures 3 and 4 give only the lower limit of the nucleophilicity of the pyrrolic substrate toward CH<sub>3</sub>FCH<sub>3</sub><sup>+</sup>, and variations of the substrate selectivity associated with changes of the reaction environment may reflect alterations of the relative efficiency of processes 1a and 1b. In spite of the largely different efficiency of collisional stabilization of I within the range of pressures investigated, the approximate constancy of the  $k_p/k_B$  ratios (Figure 3) suggests that the extent of the side processes (1b) is independent of the excitation level of I. Owing to their high proton affinity,<sup>15</sup> methyl- and dimethylpyrroles are the strongest bases present in the gaseous mixtures irradiated in the absence of NMe<sub>3</sub> (PA ≈ 229 kcal mol<sup>-1</sup>).<sup>14</sup> Therefore, deprotonation of the ionic intermediates I from the methylation of **1** and **2** can represent an endothermic, and therefore comparatively slow, process that allows a longer lifetime and a more extensive decomposition of the charged intermediates (I). Alternatively, the arenium ion II (eq 2), from

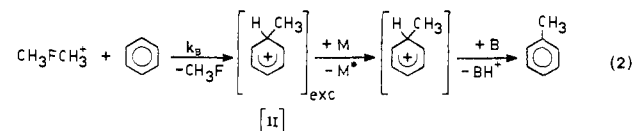

methylation of benzene, can be quenched rapidly via fast, exothermic proton transfer to other bases contained in the gas (i.e., pyrroles). These conditions explain the increases of the apparent reactivity of **2** with respect to benzene by addition of increasing amounts of NMe<sub>3</sub> in the gas (Figure 4). Indeed, NMe<sub>3</sub> ensures fast, exothermic deprotonation of all intermediates (I and II), irrespective of the different strengths of their conjugates bases. Their lifetime is leveled off as well as their extent of decomposition. On the other hand, with the addition of variable concentrations of NMe<sub>3</sub>, the insensitivity of the apparent reactivity of **1** with respect to benzene suggests that processes 1b are still significant at high pressures (760 torr). Although no reasonable explanation can be provided for such different behavior, it must nevertheless be related to the different structural features of the pyrrolic substrate.

In order to account for the isomeric composition of products from **1** and its dependence on the reaction environment (Figures 5 and 6), we suggest that the attack of CH<sub>3</sub>FCH<sub>3</sub><sup>+</sup> on pyrrole leads, in the kinetically controlled step of the reaction, to the predominant formation of the β-methylated intermediate I<sub>β</sub>. The formation of I<sub>β</sub> is accompanied by comparable yields of the N isomer I<sub>N</sub> and substantially lower amounts of the α isomer I<sub>α</sub> (eq 3). Unless deprotonated by the base (NMe<sub>3</sub>) (eq 1a), the in-

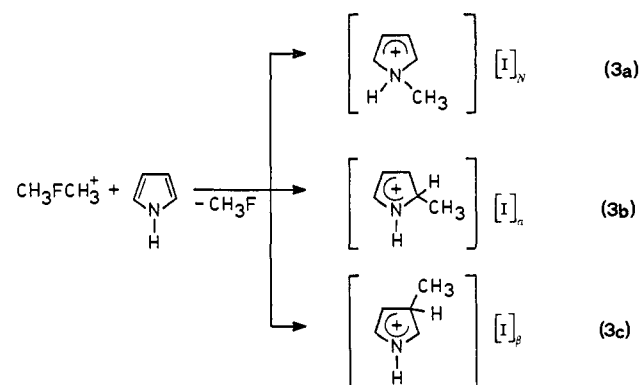

termediates I tend to isomerize to the thermodynamically most stable isomer, which, according to the experimental evidence, is a β-methylated intermediate. Structure III (R = H) can be

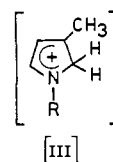

tentatively assigned to such an intermediate on the basis of the

substituent effects on heteroaromatic reactivity.<sup>2,3</sup>

It should be noted that isomerization of  $I_\beta$  to III ( $R = H$ ), which requires only a fast  $\beta \rightarrow \alpha$  intramolecular proton shift, is likely to proceed to completion in the gaseous systems investigated. Alternatively, isomerization of either  $I_N$  or  $I_\alpha$  to III ( $R = H$ ) requires in addition a slower methyl-group migration<sup>18</sup> whose extent is determined by the specific reaction environment. This is suggested by the dependence of the isomeric composition of the products on the reaction conditions. Inspection of Figures 5 and 6, however, reveals that the relative distribution of the isomeric methylpyrroles from **1** is mainly determined by the competition between the isomerization process and the deprotonation step of eq 1a (whose rate is controlled by the  $NMe_3$  concentration (Figure 6)), rather than the collisional deactivation step of eq 1a (whose efficiency is determined by the total pressure of the system (Figure 5)). This suggests that, in the absence of added  $NMe_3$ , the isomerization process of **1** is rather extensive even at relatively high pressures (760 torr), where efficient collisional quenching of **I** takes place. Moreover, it is still operative in the presence of a powerful ion interceptor, such as  $NMe_3$ , at concentration up to 5–10 times ( $P_{NMe_3} = 2\text{--}5$  torr) that of the pyrrolic substrate. On these grounds, we conclude that the  $I \rightarrow III$  ( $R = H$ ) isomerization process is likely to take place via the fast intramolecular mechanism 4, which is characterized by a relatively low activation energy.

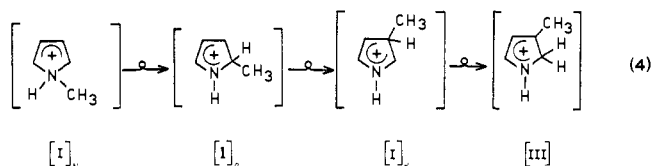

Furthermore, increase of the yield of the  $\beta$ -methylpyrrole (**4**) from **1** at low  $NMe_3$  concentrations (Figure 6) (which apparently takes place at the expense of the  $N$  isomer (**2**) without any concomitant accumulation of the  $\alpha$  isomer (**3**)) suggests that the first step of the isomerization sequence 4 is substantially slower than the following one. It follows that a relatively low steady-state concentration of the intermediate  $I_\alpha$  is present, which is independent of the initial distribution of the isomeric species **I**.

Conditions favoring kinetic control of the products occur when the extent of the isomerization process 4 is minimized, i.e., at 760 torr and in the presence of 10 torr of  $NMe_3$ . Under these conditions, the *intrinsic* positional selectivity of gaseous  $CH_3FCH_3^+$  ion toward pyrrole **1**, or at least its lower limit,<sup>19</sup> can be measured from the isomeric distribution of the methylated products ( $\beta$ , 50%;  $N$ , 35%;  $\alpha$ , 15%).

Regarding the  $CH_3FCH_3^+$  methylation of **2**, the reaction pattern is qualitatively similar to that proposed for **1**. However, Figures 9 and 10 reveal that, as opposed to **1**, the isomeric distribution of the methylated derivatives of **2** does not significantly change with the reaction conditions. In fact, the **6** vs. **5** kinetic distribution (70% vs. 30%, Figure 10) does not differ greatly from that measured at lower pressure (65% vs. 35%, Figure 9), namely

(18) (a) McLean, C.; Mackor, E. L. *Discuss. Faraday Soc.* **1962**, *34*, 165–176. (b) Field, F. H. "Ion-Molecule Reactions"; Franklin, J. L., Ed.; Butterworths: London, 1972; Vol. 1.

(19) It must be taken into account that the positional selectivity observed at 760 torr and in the presence of 10 torr of  $NMe_3$  is based on the results obtained under conditions where effective deactivation and fast deprotonation of excited intermediates **I** reduce, if not eliminate, isomerization processes. In other words, the question arises as to whether the isomeric composition of products measured under such conditions reflects the actual selectivity of  $CH_3FCH_3^+$  attack on the substrates or whether there is any residual contribution from fast intramolecular methyl-group shifts within ionic intermediates **I**. However, the tendency of the curves of Figure 6 to level off at  $NMe_3$  partial pressures greater than 10 torr suggests that, if there is any residual isomerization within **I** ( $R = H$ ), it is so limited that its effect on the actual directive properties of pyrrole toward  $CH_3FCH_3^+$  falls within the experimental uncertainty. Any attempt to experimentally substantiate this conclusion, e.g., by adding higher concentrations of  $NMe_3$  to the gaseous mixture, was frustrated by the prohibitively low yields of methylpyrroles, which make the determination of their relative distribution affected by an exceedingly high error.

under conditions favoring thermodynamic control of products. Such behavior might be accounted for by either an exceedingly high energy barrier for any conceivable methyl group migration within the corresponding intermediates **I** ( $R = CH_3$ ) or a coincidence between the kinetic ( $I_\beta$  vs.  $I_\alpha$ ) and thermodynamic (III vs. IV) distributions of the isomeric methylated derivatives of **2** (eq 5). The former hypothesis would be in contrast to the rather

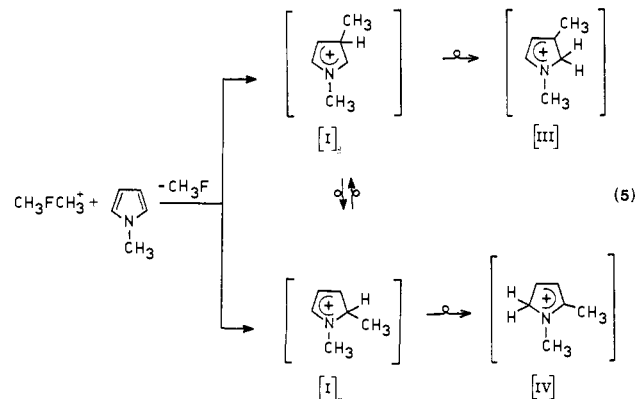

low activation energy characterizing isomerization of **I** ( $R = H$ ) from **1**.

The latter hypothesis could be substantiated by the results of the competition experiments reported in Figures 11 and 12. Here the presence of benzene leads to a significant enhancement of the relative yield of **5** (**6**:**5** = 1.1 at 760 torr). It suggests a preferential attack of **II** to the  $\alpha$  positions of *N*-methylpyrrole (eq 6).

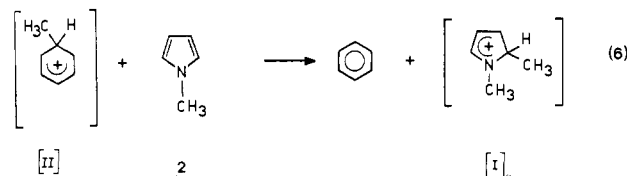

However, in the presence of high amounts of a suitable interceptor ( $NMe_3$ ) (Figure 12), extensive intermolecular methyl transfer (eq 6) is prevented. As a consequence, a kinetic distribution of the isomeric dimethylpyrroles **5** and **6** is observed (**6**:**5** = 2.1) which roughly matches that measured in the absence of benzene (**6**:**5** = 2.4). At low pressures and in the absence of  $NMe_3$  (Figure 11), namely under conditions where not only process 6 is allowed but also extensive intramolecular isomerization within  $I_\alpha$  can take place, the relative yield of **5** decreases again in favor of the  $\beta$ -methylated isomer. The relative distribution, then, tends to the same thermodynamic distribution that is measured from the systems containing only **2** as the substrate (**6**:**5** = 1.8). These findings, therefore, show an equivalence between a  $I_\beta$  vs.  $I_\alpha$  kinetic distribution and the corresponding III vs. IV distribution, which is favored under thermodynamically controlled conditions (eq 5). Furthermore, the significant pressure effect on the  $\alpha$ : $\beta$  ratio of Figure 11 indicates that any conceivable methyl-group shifts within **I** ( $R = CH_3$ ) are characterized by moderate activation barriers.

Within this framework, a quantitative estimate of the *inherent* positional selectivity of  $CH_3FCH_3^+$  ion toward *N*-methylpyrrole, as well as of the relative thermodynamic stability of III and IV, can be directly deduced from the isomeric distribution of the corresponding neutral derivatives **5** and **6**. This is valid provided that no  $CH_3FCH_3^+$  attack on the heteroatom of **2** takes place. If  $CH_3FCH_3^+$  ion would attack the heteroatom of **2**, it would lead to the formation of the hypothetical ammonium ion  $I_N$  ( $R = CH_3$ ),

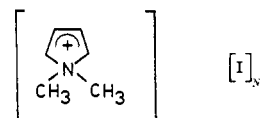

which, in contrast to the C-methylated intermediates  $I_\alpha$  and  $I_\beta$  ( $R = CH_3$ ) of eq 5, would not collapse into isolable methylated derivatives without preliminary isomerization to a C-alkylated

isomer by a mechanism analogous to eq 4. In this connection, appreciable decrease of the 6:5 yield ratio should be observable under conditions allowing  $I_N \rightarrow I_\alpha \rightarrow I_\beta$  isomerization. This result should be particularly evident at relatively high pressures (400–760 torr), since the second step of the isomerization sequence appears sufficiently slow to be effectively prevented by collisional stabilization of the excited intermediate  $I_\alpha$  (cf. Figures 9 and 11). Observation of a constant 6:5 yield ratio, irrespective of the experimental conditions (Figures 9 and 10), excludes therefore significant  $\text{CH}_3\text{FCH}_3^+$  ion attack on the N atom of **2**. This conclusion is further substantiated by independent experiments demonstrating the scarce reactivity of the N atom of **2** toward even more powerful electrophiles such as  $\text{H}_3^+$ . The methylation reaction pattern of **1** shows that, when  $I_N$  ( $R = \text{H}$ ) is generated in the absence of  $\text{NMe}_3$ , it readily isomerizes to give predominantly  $I_\beta$ , via the intermediacy of  $I_\alpha$ . This propensity can therefore be used to demonstrate or exclude the formation of  $I_N$  by protonation of *N*-methylpyrrole by the strong Brønsted acid  $\text{H}_3^+$  ( $\Delta H_f^\circ = 262 \text{ kcal mol}^{-1}$ ).<sup>20</sup> It should be noted that the excitation energy of  $I_N$ , hypothetically formed from reaction 7, is significantly higher

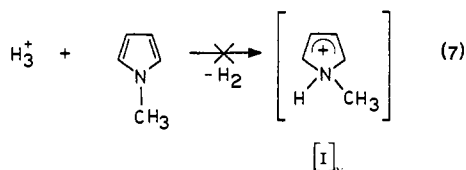

than that from reaction 3a. The reaction environment is also somewhat different, since replacement of  $\text{CH}_3\text{F}$  with  $\text{H}_2$  as the bulk constituent of the gas is likely to affect the efficiency of collisional stabilization.

Notwithstanding the fact that these differences should further favor isomerization of  $I_N$ , if formed from reaction 7, the results of the  $\text{H}_3^+$  protonation experiments did not display any detectable formation of **1**, **3**, and **4** from **2**. Taking into account that **3** and **4** are major products from the isomerization of  $I_N$  when generated by  $\text{CH}_3\text{FCH}_3^+$  attack on the N atom of pyrrole **1**,<sup>21</sup> it can be concluded that  $I_N$  is not formed by attack of  $\text{H}_3^+$  on **2**, thus providing strong evidence against appreciable reactivity of the N atom of **2** even toward relatively powerful ionic electrophiles.

**Reactivity and Selectivity of Gaseous  $\text{CH}_3\text{FCH}_3^+$  Ions.** The use of the experimental  $k_p/k_B$  ratios and isomeric composition of products as a basis for evaluating the reactivity and selectivity of gaseous  $\text{CH}_3\text{FCH}_3^+$  ions is open to question, owing to the complex character of the reaction pattern following the gas-phase attack of  $\text{CH}_3\text{FCH}_3^+$  on pyrroles **1** and **2**. Nevertheless, considering only the methylation data obtained at the highest  $\text{CH}_3\text{F}$  and  $\text{NMe}_3$  pressure (i.e., under conditions where effective deactivation and deprotonation reduce, if not eliminate,<sup>19</sup> secondary processes), assessment of the *intrinsic substrate* and *positional* selectivities of  $\text{CH}_3\text{FCH}_3^+$  toward pyrroles is possible.

The *substrate* selectivity of gaseous  $\text{CH}_3\text{FCH}_3^+$  ion toward pyrroles, inferred from the corresponding  $k_p/k_B$  value ( $>0.4$  (**1**),<sup>22</sup> 1.0 (**2**)), appears quite low by solution chemistry standards. This is in sharp contrast with its remarkable *positional* selectivity, which is reflected by the kinetic predominance (50% for **1**, 70% for **2**) of  $\beta$  methylation. The contrast between a poor substrate dis-

crimination and a respectable positional selectivity (that has been shown<sup>23</sup> to represent a typical feature of gas-phase aromatic substitutions by charged electrophiles) is therefore confirmed by the present study.

Concerning *positional* selectivity, the *intrinsic* directive properties of pyrrole **1** toward gas-phase electrophilic  $\text{CH}_3\text{FCH}_3^+$  methylation demonstrate the distinct tendency of the heteroaromatic substrate to direct the electrophile toward the ring centers having the maximum value of the net negative charge,<sup>4,6</sup> i.e., the N and  $C_\beta$  atoms. These findings are in complete agreement with recent semiempirical calculations of the ground-state molecular potentials that are generated by the interaction between a positive point charge and an isolated molecule of pyrrole or *N*-methylpyrrole.<sup>7</sup> The relevant equipotential energy contours show, in fact, that both the  $\beta$  positions and the heteroatom of an undistorted pyrrole molecule should represent the preferred sites of attack for an approaching charged electrophile. The agreement between these theoretical predictions and the present gas-phase results also applies to the directive properties of the pyrrolic substrate as a function of the substituent on the N atom.

Semiempirical calculations of the electrostatic potential induced around **1** or **2** show, in fact, that the presence of relatively acidic<sup>24</sup> hydrogens in the N–H moiety of **1** and in the  $\text{CH}_3$  group of **2** hinders establishment of an effective negative potential region around the heteroatom and that such hindrance is more pronounced for N– $\text{CH}_3$ . This is valid as long as the N–R bond is in the ring plane. Taking into account that the  $\text{CH}_3$  group of **2** is more difficult to displace from the ring plane than N–H of **1**,<sup>25</sup> the relatively minor affinity of  $\text{CH}_3\text{FCH}_3^+$  toward the N atom of **2**, in spite of the high electron density located on the heteroatom, finds a plausible explanation.<sup>26</sup>

In conclusion, the gas-phase results are in agreement with the most common ion-polar molecule collision theories, pointing to the attractive electrostatic interaction between the ionic electrophile and the negative end of the polar substrate as one of the main factors governing site selection in gas-phase ion-molecule reactions.<sup>27</sup> However, the present study indicates that other factors, related to the structural and electronic features of the substituent groups of the substrate, may appreciably modify the selectivity picture based on purely electrostatic arguments.

**Comparison with Solution Chemistry Data.** In the specific case of methylation, there is little or no information from the already limited body of experimental work concerning Friedel-Crafts alkylations of pyrrole or any of its simplest derivatives that can be used for a kinetically significant comparison with the present gas-phase results. The only available condensed-phase data pertain to aluminum chloride catalyzed Friedel-Crafts *tert*-butylation of pyrrole at  $-80^\circ\text{C}$ , giving low yields of a ca. 1:0.8 mixture of 2- and 3-*tert*-butylpyrrole, accompanied by considerable polymerization.<sup>12</sup> It is evident that no correspondence exists between the directive properties of simple pyrroles, observed in the gas phase, and those measured in solution for the most common electrophilic substitution,<sup>2,3,12</sup> even though carried out under conditions (low temperatures, low conversion, etc.) designed to reduce as much as possible secondary isomerization and polymerization. This discrepancy, as well as that concerning the exceedingly wide reactivity span from **2**, **1**, and benzene in solution, points to the

(20) The  $\text{H}_3^+$  acid was obtained in the dilute gas state from the  $\gamma$  radiolysis of  $\text{H}_2$  at 400 torr (cf.: (a) Ausloos, P.; Lias, S. G. *J. Chem. Phys.* **1964**, *40*, 3599–3605. (b) Aquilanti, V.; Giardini-Guidoni, A.; Volpi, G. G. *Trans. Faraday Soc.* **1968**, *64*, 3282–3287. (c) Cacace, F.; Cipollini, R.; Occhiucci, G. *J. Chem. Soc., Perkin Trans. 2* **1972**, 84–88).

(21) The same experiment, carried out in the presence of 10 torr of  $\text{NMe}_3$ , did not show any formation of dimethylpyrroles (**5** and **6**), excluding, therefore,  $\text{NMe}_3$  as an additional source of methylating species and confirming  $\text{CH}_3\text{FCH}_3^+$  as the unique methylating reactant in the  $\text{CH}_3\text{F}$  radiolytic experiments.

(22) Taking into account the rather low sensitivity of the secondary fragmentation process (1b) involving I ( $R = \text{H}$ ) to the presence of  $\text{NMe}_3$ , a  $k_p/k_B$  ratio ranging from 0.4 to ca. 1.0 would best correspond to the actual selectivity of  $\text{CH}_3\text{FCH}_3^+$  toward the pyrrole/benzene pair. The upper limit of  $k_p/k_B$  ratio from **1** is arrived at by assuming no residual secondary processes for I ( $R = \text{H}$ ) at 760 torr and in the presence of 10 torr of  $\text{NMe}_3$ , as in the case of **2**.

(23) (a) Suhr, H. *Chem. Ber.* **1964**, *97*, 3268–3277. (b) Attinà, M.; Cacace, F.; Ciranni, G.; Giacomello, P. *J. Am. Chem. Soc.* **1977**, *99*, 4101–4105. (c) *Ibid.* **1977**, *99*, 5022–5025. (d) *Ibid.* **1977**, *99*, 2611–2615.

(24) Bartmess, J. E.; Scott, J. A.; McIver R. T., Jr. *J. Am. Chem. Soc.* **1979**, *101*, 6046–6063.

(25) Scott, D. W. *J. Mol. Spectrosc.* **1971**, 77–84.

(26) It is interesting to note that the authors of ref 7a,b advanced a synchronous double bending of the N–H ( $30^\circ$ ) and  $C_\alpha$ –H ( $52^\circ$ ) bonds out of the ring plane to induce formation of a negative potential region around  $C_\alpha$  of pyrrole and, therefore, to provide a theoretical justification for the predominant  $\alpha$  substitution observed in solution. The present results, obtained in the dilute gas phase, i.e., under conditions much more suited for a comparison with theoretical predictions, underline the unnecessary of the above assumptions.

(27) (a) Bowers, M. T.; Su, T. "Interactions between Ions and Molecules"; Ausloos, P., Ed.; Plenum Press: New York, 1974. (b) Chesnavich, W. J.; Su, T.; Bowers, M. T. "Kinetics of Ion Molecule Reactions"; Ausloos, P., Ed.; Plenum Press: New York 1979.

influence of the reaction medium (solvation, ion pairing, catalyst, etc.) as the main factor responsible for the reactivity and selectivity features of pyrroles toward electrophilic substitution in solution.

**Acknowledgment.** We are indebted to the Mass Spectrometry Service of the Area della Ricerca di Roma, C.N.R., Italy, for

running the CIMS experiments.

**Registry No.** 1, 109-97-7; 2, 96-54-8; I (R = H), 83437-09-6; I (R = Me), 83437-11-0; III (R = H), 83437-10-9; III (R = Me), 83447-52-3; MeF, 593-53-3; MeCl, 74-87-3;  $\text{CH}_3\text{FCH}_3^+$ , 64710-12-9;  $\text{CH}_3\text{ClCH}_3^+$ , 24400-15-5;  $\text{NMe}_2$ , 75-50-3;  $\text{O}_2$ , 7782-44-7; benzene, 71-43-2.

## Gas-Phase Heteroaromatic Substitution. 3.<sup>1</sup> Electrophilic Methylation of Furan and Thiophene by $\text{CH}_3\text{XCH}_3^+$ (X = F or Cl) Ions

Giancarlo Angelini, Gaetano Lilla, and Maurizio Speranza\*

Contribution from the Istituto di Chimica Nucleare del C.N.R., Area della Ricerca di Roma, C.P. 10, Rome, Italy. Received September 17, 1982

**Abstract:** A previous radiolytic study on the gas-phase methylation of pyrrole and *N*-methylpyrrole by  $\text{CH}_3\text{XCH}_3^+$  (X = F or Cl) ions, from the  $\gamma$  radiolysis of  $\text{CH}_3\text{X}$ , is extended to furan (3) and thiophene (4). The mechanism of the substitution and of the subsequent isomerization occurring via intramolecular 1,2 methyl-group shifts is discussed and the *substrate* and *positional* selectivity of the selected electrophilic species evaluated. As for pyrroles, gas-phase  $\text{CH}_3\text{FCH}_3^+$  methylation of furan and thiophene is characterized by a scarce substrate discrimination ( $k_S/k_B = 1.2$  (3), 0.8 (4)), accompanied by an appreciable positional selectivity toward those substrate positions with the highest negative net charge (O: $\alpha$ : $\beta$  = 36%:35%:29% for 3; S: $\alpha$ : $\beta$  = 19%:43%:38% for 4). On the contrary,  $\text{CH}_3\text{ClCH}_3^+$  confirms its inherent affinity toward n-type nucleophilic centers by attacking preferentially the heteroatom of 3 and 4. In light of the previous results concerning  $\text{CH}_3\text{XCH}_3^+$  methylation of pyrroles, it is concluded that gas-phase attack of  $\text{CH}_3\text{XCH}_3^+$  on simple five-membered heteroaromatics is essentially regulated by the electrostatic interaction established within the encounter pair. A close correspondence does exist between this rationalization of the present gas-phase results and recent theoretical predictions.

In the preceding papers of this series, the application of a specifically designed radiolytic technique for the study of heteroaromatic substitution by  $\text{CH}_3\text{XCH}_3^+$  (X = F or Cl) ions in the dilute gas state has been reported.<sup>1</sup> In particular, the *intrinsic* reactivity features of pyrrole (1) and *N*-methylpyrrole (2) toward gaseous  $\text{CH}_3\text{XCH}_3^+$  ions have been evaluated.  $\text{CH}_3\text{FCH}_3^+$  ions displayed a scarce *substrate* selectivity, coupled with a remarkable *positional* discrimination, in its electrophilic attack on the pyrrolic substrates. In fact, extensive attack on  $\beta$ -carbons of the heterocyclic compound was observed in the gaseous phase in contrast with the evidence available from related substitutions in solution.<sup>2</sup> These findings are in agreement with most advanced theoretical predictions.<sup>3-5</sup> Instead, the  $\text{CH}_3\text{ClCH}_3^+$  ion confirmed its peculiar affinity toward n-type centers<sup>6</sup> by displaying its scarce reactivity

even toward  $\pi$ -electron-rich compounds, such as pyrrole (1) and *N*-methylpyrrole (2).

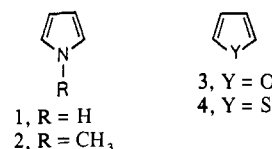

With the aim of confirming the validity of such relationship, the investigation has been now extended to the determination of the reactivity features of  $\text{CH}_3\text{XCH}_3^+$  (X = F or Cl) ions toward other simple five-membered heteroaromatics, containing both n- and  $\pi$ -type nucleophilic sites, i.e., furan (3) and thiophene (4). It is expected that this study would also lead to the assessment of a unified *intrinsic* reactivity scale for simple heteroaromatics toward the  $\text{CH}_3\text{XCH}_3^+$  ions, which are known to be involved in Friedel-Crafts methylation reactions by methyl halides.<sup>7</sup> It is thereby hoped to provide a simplified model linking gas-phase heteroaromatic substitutions to the related reactions occurring in solution. Interpretation of these results is, in fact, severely hampered by the recognized effects of solvation, ion pairing, catalysts, etc. and the other complicating phenomena related to the reaction environment.<sup>2</sup>

### Experimental Section

**Materials.** Furan, 2-methylfuran, thiophene, 2- and 3-methylthiophenes, and benzene are commercially available from ICN Pharmaceutical, Inc., and Fluka AG. 3-Methylfuran was prepared according to established procedures.<sup>8</sup> Immediately before use, these compounds

(1) Presented in part at the 8th International Congress of Heterocyclic Chemistry, Graz, Austria, Aug 1981. Part 1: Speranza, M. *J. Chem. Soc., Chem. Commun.* 1981, 1177-1178. Part 2: Angelini, G.; Sparapani, C.; Speranza, M. *J. Am. Chem. Soc.*, preceding paper in this issue.

(2) For comprehensive reviews, see: (a) Marino, G. *Adv. Heterocycl. Chem.* 1971, 13, 235-314. (b) Katritzky, A. R.; Lagowsky, J. M. "The Principles of Heterocyclic Chemistry"; Academic Press: New York, 1968. (c) Albert, A. "Heterocyclic Chemistry", 2nd ed., Oxford University Press: New York, 1968. (d) Jones, R. A. *Adv. Heterocycl. Chem.* 1970, 11, 383.

(3) (a) Abronin, I. A.; Belenkii, L. I.; Gol'dfarb, Ya. L. "New Trends in Heterocyclic Chemistry"; Elsevier: North-Holland, 1979. (b) Ridd, J. *Phys. Methods Heterocycl. Chem.* 1971, 4, 55-120. (c) Jones, R. A.; Bean, G. P. "The Chemistry of Pyrroles"; Academic Press: New York, 1977.

(4) (a) Catalan, J.; Yanez, M. *J. Chem. Soc., Perkin Trans. 2* 1979, 1627-1631. (b) Palmer, M. H.; Gaskell, A. *J. Theor. Chim. Acta* 1971, 23, 52-58. (c) Kramling, R. W.; Wagner, E. L. *Ibid.* 1969, 15, 43-56.

(5) (a) Politzer, P.; Weinstein, H. *Tetrahedron* 1975, 31, 915-923. (b) Chou, D.; Weinstein, H. *Ibid.* 1978, 34, 275-286. (c) Politzer, P.; Donnelly, R. A.; Daiker, K. C. *J. Chem. Soc., Chem. Commun.* 1973, 617-618. (d) Berthier, G.; Bonaccorsi, R.; Scrocco, E.; Tomasi, J. *Theor. Chim. Acta* 1972, 26, 101-105.

(6) (a) Speranza, M.; Pepe, N.; Cipollini, R. *J. Chem. Soc., Perkin Trans 2* 1979, 1179-1186. (b) Pepe, N.; Speranza, M. *Ibid.* 1981, 1430-1436. (c) Speranza, M.; Angelini, G. *J. Am. Chem. Soc.* 1980, 102, 3115-3120. (d) Angelini, G.; Speranza, M. *Ibid.* 1981, 103, 3792-3799. (e) *Ibid.* 3800-3806. (f) Colosimo, M.; Bucci, R. *J. Phys. Chem.* 1979, 83, 1952-1957.

(7) (a) Olah, G. A. "Halonium Ions"; Olah, G. A., Ed.; Wiley: New York, 1975. (b) Olah, G. A.; DeMember, J. R. *J. Am. Chem. Soc.* 1970, 92, 718-720. (c) Olah, G. A.; Melby, E. G. *Ibid.* 1972, 94, 6220-6221. (d) Olah, G. A.; Yamada, Y.; Spear, R. J. *Ibid.* 1975, 97, 680-681. (e) Peterson, P. E.; Brockington, R.; Vidrine, D. W. *Ibid.* 1976, 98, 2660-2661. (f) Olah, G. A.; Donovan, D. J.; Lin, H. C. *Ibid.* 2661-2663.

(8) Sherman, E.; Amstutz, E. D. *J. Am. Chem. Soc.* 1950, 72, 2195-2199.